

MOTHER- DAUGHTER TOTE BAG

Patchwork mini-tote bag to showcase four fabrics (plus lining) of your choice. Perfect size for grown-ups and girls of all sizes.

SUGGESTED FABRICS: Light- to medium-weight woven fabrics like quilting cotton, broadcloth, lawn, shirting, poplin, silk taffeta or dupioni, and linen.

NOTIONS: Coordinating thread, medium-weight fusible interfacing.

YARDAGE REQUIREMENTS: 1/2 yard of fabric A (for stripe 1 and straps), one fat quarter each of fabrics B, C, and D (for stripes 2-4), and 3/4 yard of fabric E (for lining and inside pocket).

FINISHED DIMENSIONS: 10" wide x 8 3/8" tall x 3 1/2" deep.

PATTERN PIECES

STRAPS: Cut 2 from fabric A, cut 2 interfacing: 16" high x 4" wide

STRIPE 1: Cut 2 from fabric A, cut 2 interfacing: 4 1/2" high x 14 1/2" wide

STRIPE 2: Cut 2 from fabric B, cut 2 interfacing: 3 1/4" high x 14 1/2" wide

STRIPE 3: Cut 2 from fabric C, cut 2 interfacing: 3 1/4" high x 14 1/2" wide

STRIPE 4 (BASE): Cut 1 from fabric D, cut 1 interfacing: 8" high x 14 1/2" wide

LINING: Cut 1 from fabric E: 21" high x 14 1/2" wide

INSIDE POCKET: Cut 2 from fabric E, cut 1 interfacing: 5 1/2" high x 8" wide

NOTE: All seam allowances are 1/2" unless otherwise indicated.

SEWING INSTRUCTIONS

PREPARE THE FABRIC

1. Once you've cut out each of the pattern pieces in the correct number, fuse each piece of interfacing to the wrong side of the corresponding fabric, following the interfacing manufacturer's instructions.

MAKE THE STRAPS

1. Fold one of the 16" x 4" strips for the straps in half lengthwise, with wrong sides together, and press the crease to create a center fold line.

2. Open the strap, and lay it flat and wrong side up. Fold each long raw edge in toward the center crease, and press the folds.



3. Fold the strap in half again (along the center line formed in Step 1), and press it, enclosing its raw edges in the fold. The strap is now folded into four fabric thicknesses.

4. Edgestitch the strap near the open edge, and edgestitch it again along the opposite folded edge to finish it. Use tailor's chalk or a water-soluble fabric pen to make a mark 1/2" from each short end of the straps.

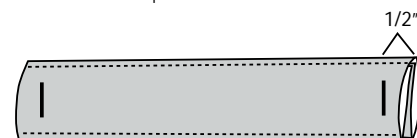

5. Repeat steps 1-4 to make the other strap.

PIECE THE OUTSIDE OF THE BAG

1. Pin one long side of one stripe #3 piece to one long side of stripe #4, with right sides together. Stitch the edges with a 1/2" seam. Pin and stitch the second stripe #3 piece to the other side of stripe #4.

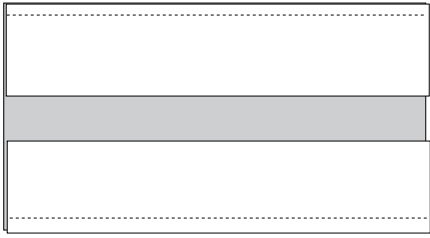

HINT: If you've selected a directional fabric (one with a distinct up and down to it), be sure to position each of the stripes so the bottom of the print is pinned and stitched to the base fabric.

2. Press the seam allowances open.

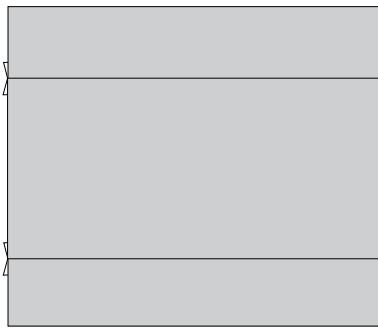

3. Pin the stripe #2 pieces to the stripe #3 pieces, stitching and pressing the seam allowances open as you did with stripe #3.

4. Pin both stripe #1 pieces to the long edges of stripe #2, pressing the seam allowances open as you did with stripes #3 and #2 previously.

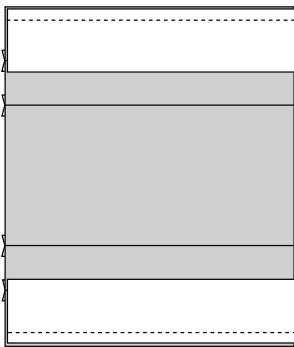

5. Once all the seams are pressed open, the outside of the bag will be one long rectangle with the base of the bag at the center.

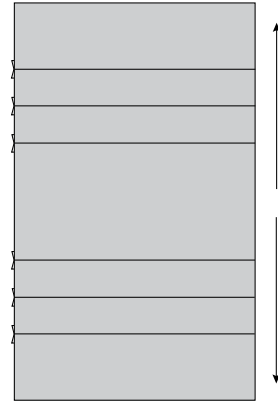

ASSEMBLE THE OUTSIDE BAG

1. Fold the bag in half, with right sides together, pinning the sides. As you pin, match the pieced seams. Stitch the sides with a 1/2" seam, backstitching or lockstitching at both ends of the seam.

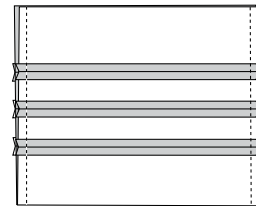

2. Press the seam allowances open, and press a crease into the folded base of the bag.

3. Open up the bag (keep it inside out) and fold one side seam to match the creased bottom fold. Pin the side seam to the crease, and use a ruler and tailor's chalk or a water-soluble fabric pen to draw a line perpendicular to the side seam, 1 3/4" from the point of the corner. Then stitch along the line you've drawn, backstitching at both ends of the stitching.

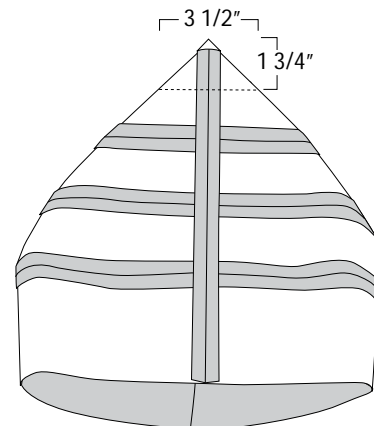

4. Trim the seam allowances to 1/2", cutting the corner from the bag.

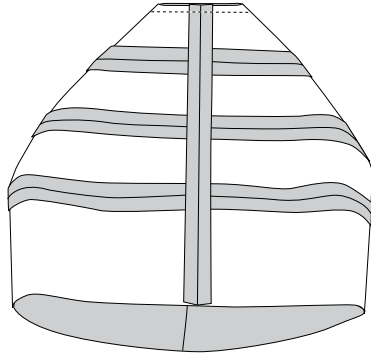

5. Fold, stitch, and trim the second corner of the bag in the same way.

MAKE AND ATTACH THE INSIDE POCKET

1. Align and pin the two cut inside pocket pieces, with right sides together. Stitch the perimeter with a 1/2" seam, starting at the raw edges, and leaving an opening for turning the pocket right side out at the bottom. (Note that when leaving an opening for turning the pocket right side out, by starting and ending your stitching at the seam allowances' raw edges, the seam allowances will be forced inside the opening when you turn the pocket right side out.) Clip the corners, and trim the seam allowances, except at the opening, to about 1/8"; then turn the pocket right side out through the opening. Use a knitting needle or chopstick to gently push out the corners, and tuck the seam allowances into the opening, so they don't show. Press the pocket flat.

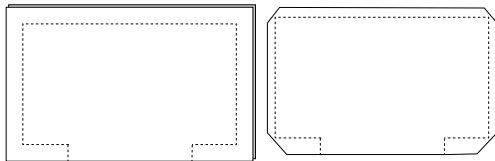

2. Position the pocket on the lining panel 3 1/2" from one short edge and centered across the width of the lining, with the opening at the bottom of the pocket (the side nearest the center of the lining). Edgestitch the sides and bottom of the pocket, which will also close the opening.

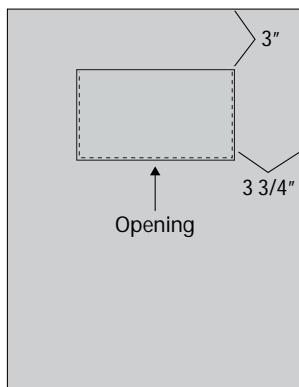

3. Using chalk or a water-soluble fabric pen, draw a line down the center of the pocket. Topstitch the dividing line you've drawn, backstitching or lockstitching at the beginning and end of the seam to secure it.



ASSEMBLE THE LINING

1. Fold the lining piece in half, with right sides together, and stitch the short sides with a 1/2" seam.

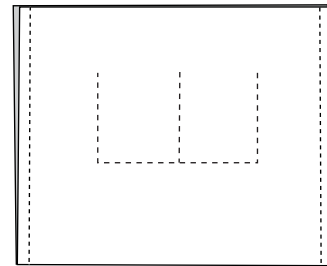

2. Press the seam allowances open, and press a crease into the folded base of the bag lining.

3. Fold and pin one corner of the bag, matching the seam to the creased fold. Then use a ruler and tailor's chalk or a water-soluble fabric pen to draw a line perpendicular to the seam line, 1 3/4" from the point of the corner. Then stitch along the line you've drawn, backstitching at both ends of the stitching.

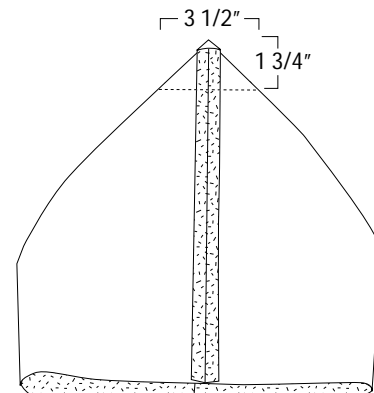

4. Trim the seam allowances to 1/2", cutting the corner from the bag lining.

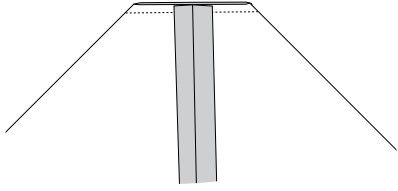

5. Fold, stitch, and trim the second corner of the bag lining in the same way.

ASSEMBLE THE BAG

1. Turn the lining right side out, and turn the outside bag inside out. Fold and press the top edge of the outside bag to the wrong side by 1/2".

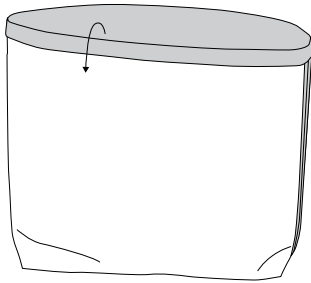

2. Fold and press the top edge of the outside bag a second time by 1". Then unfold just this fold, leaving the crease in place.

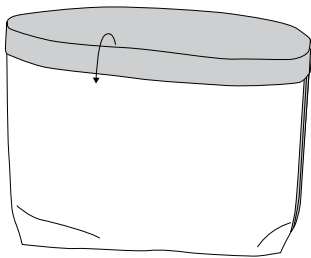

3. Slip the outside bag into the lining and match the corners and side seams before pinning them together. The raw top edge of the lining will reach the creased fold in step #2, above. Re-fold the top edge of the outside bag to cover the raw edge of the lining. Pin the layers to hold them in place temporarily.

4. Use a pin, tailor's chalk or a water-soluble fabric pen to mark the top edge of the bag, 3 1/2" from each side seam. Slip the ends of one strap under the folded edge of the bag so the outside edge of the strap meets the markings. Insert just 1/2" of the strap under the folded edge so you won't have too much bulk in the finished strap. (Use the 1/2" markings you made on the ends of the straps to help with this.) Edgestitch the innermost fold of

the bag, catching the end of the straps and the top of the lining in your stitching. Repeat to attach the second strap.

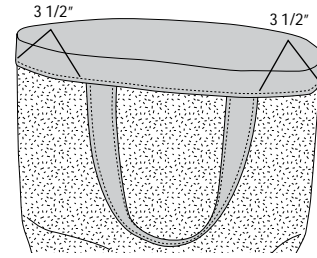

5. Fold and press the straps toward the top of the bag and pin them in place. Edgestitch the top of the bag at the location of the straps to hold them in place or, alternatively, edgestitch the entire top of the bag to finish it.

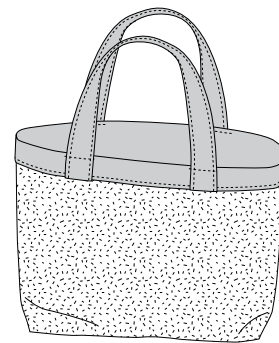

oliver + s discussion forums

For answers to sewing questions,
visit the discussion forums on our website:
www.oliverands.com/forums

oliver + s

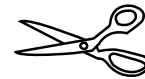

New York, NY

This pattern is for private use only. The images, layout, design and other aspects of this pattern are copyright © Liesl + Co., Inc. 2010. If you wish to make and sell items from this pattern, please contact us for terms. Otherwise, no part of this design or pattern may be reproduced in any form.

www.oliverands.com

3 5 7 9 10 8 6 4 2